

# PBM FIRE RATED TANK BOTTOM VALVE

## Industrial Tank Bottom Series 6, 1/2" - 3"



### DESIGN FEATURES:

- Fire Rated, tested to API-607
- Valves shall be a three-piece "swing-out" body design.
- Valves meet ASME B16.34 in appropriate materials and ends.
- Pad radius facilitates efficient drainage and reduces the pocket area above the ball.
- Upstream and downstream bubble-tight sealing capability allows valve body cleaning, purging, and draining.
- Stem assembly accommodates PBM Direct Mount Actuation for accurate alignment and increased cycling life.
- Available in Angle Stem versions for applications where automation may interfere with tank head or jacket.
- Valves are rated for full vacuum.
- Standard bottom-entry stem provides protection from inadvertent stem removal. Engagement between the slot and ball is specially designed for high torque applications.



SPECIFICATIONS	2-Way Fire Rated Tank Bottom Valves
Sizes	1/2" - 3" depending on series
Material	316L, (ASTM A351 CF3M), Hastelloy® C276 and other ASME B16.34 materials
Temperatures	Ambient for TFM™ to 400° F, S-TEF® to 450° F
End Connections	Buttweld, Flange, NPT, Socket Weld, others
Seats & Seals	White TFM™ standard, others available
Stem Packing Material	TFM™ or S-TEF® Seats, Graphite seals, O-rings (EPR, Viton standard)
Body Bolts & Nuts	18-8 Stainless Steel, Fully encapsulated
Maximum Working Pressure	up to 700 psig depending on valve series, size and temperatures
Temperatures	Ambient for TFM™ to 400° F, S-TEF® to 450° F

CV Values (gpm), FT Series 6	
Size	End Connection
1/2"	14
3/4"	42
1"	70
1-1/2"	190
2"	370
3"	900

### Custom pads for special applications

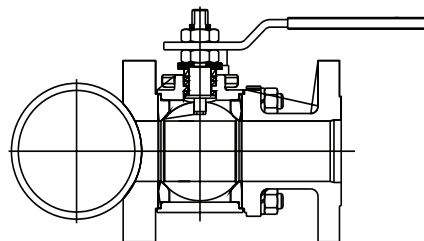

Cylindrical radius pads or reduced pocket cylindrical radius pads accommodate customer-specified or existing valve products.

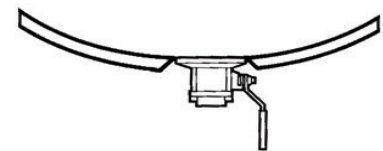

Spherical radius pads or reduced pocket spherical radius pads facilitate efficient drainage and reduces the pocket area above the ball.

### How To Order:

PRODUCT (1-2)		SIZE (5)		END CONN.		SEAT & SEAL		Weld Pad		BALL & STEM		OPERATOR		POLISH			
MATERIAL (3-4)		SERIES (6)		(7-8)		(9)		(10-11)		(12)		(13-14)		(15-16)			
FT	H-	Cast 316/316L S / S	C	1/2"	6	B-	Sch. 40 Butt Weld	G	TFM™ Seats / Graphite Seals / FKM O-Rings	--	Standard Weld Pad	-	Standard Ball and Stem	--	W/ Standard Lever Handle	-	125 Ra ID Standard
	HL	Cast 316L S / S	D	3/4"		D-	Sch. 10 Butt Weld	J	TFM Seats / Graphite Seals / VTFE Cav Fill / FKM O-Rings	02	w/o weld pad w/ shipping pad	G	17-4PH Stem	02	W/O Handle W/ Stem Actuator Prep	A	20 Ra ID
	C-	Hastelloy C-276	E	1"		L-	150# Flange	Z	TFM Seats / Graphite Seals / EPR O-Rings	Other Weld Pad Options available - Contact PBM.				04	Locking Lever Handle	C	20 Ra ID / 32 Ra OD
	Y-	Hastelloy C-22	G	1-1/2"		M-	300# Flange							18	Extended Handle (1/2" thru 3")		
			H	2"		Q-	Female NPT	2	TFM Seats / Graphite Seals / VTFE Cav Fill / EPR O-Rings					20	DA 80psig actuator	F	20 Ra ID after Electro Polish
	P-	AL6XN	K	3"		U-	Socket Weld							27	DA 60psig actuator		
								H	S-TEF® Seats / Graphite Seals / FKM O-Rings					34	SR 80psig actuator		More polish available - Contact PBM.
								0	S-TEF® Seats / Graphite Seals / EPR O-Rings					41	SR 60psig actuator		
								9	TFM Seats / Seals / FEP Encaps. / FKM O-Rings								

Other material options available - Contact PBM.

Other operator options available - Contact PBM.

Other Seat/seal options available - contact PBM.

# PBM Fire Rated Flush Tank Series 6 Manual

Flush Tank Valve with Locking Handle

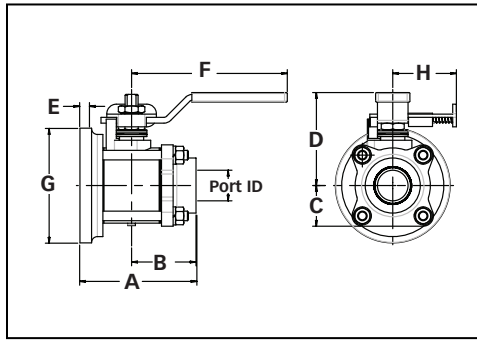

Flush Tank Valve with Ext. Locking Handle

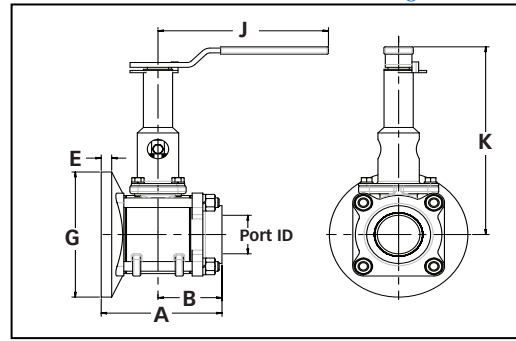

Flush Tank Fire Rated Valve Dimensioned Valves in inches

Valve Size	Size Code	I.D. Port	A		B		¢ to Bottom	¢ to Top	Pad Thick.	Length from ¢	Pad Dia.	End Fitting	Locking Handle		Ext Lock Handle		Approx Weight	
			Q-	L-	Q-	L-	C	D					Q-	Hole Dia.	J	K	Q-	L-
1/2"	C	0.5	2.83	4.02	1.56	2.75	0.98	2.63	0.28	4.15	2.75	3.50	2.75	.25	7.19	5.09	2 lbs.	3 lbs.
3/4"	D	0.75	3.07	4.23	1.72	2.88	1	2.78	0.31	4.15	3	3.88	3	.25	7.19	5.09	2.5 lbs.	4 lbs.
1"	E	1.00	3.84	4.96	2.13	3.25	1.33	3.1	0.32	5.09	3.75	4.25	3.75	.28	7.34	5.09	5 lbs.	7 lbs.
1-1/2"	G	1.5	5.07	6.32	2.75	4.00	1.78	4.41	0.46	8.68	5.5	5.00	5.5	.38	7.62	5.09	13 lbs.	16 lbs.
2"	H	2.0	5.66	7.54	3.00	4.88	2.2	4.7	0.49	8.68	6.5	6.00	6.5	.38	9.76	8.00	19 lbs.	25 lbs.
3"	K	3.0	8.38	10.26	4.50	6.38	3.1	6.78	0.77	12.44	9	7.50	9	.38	11.69	12.06	57 lbs.	68 lbs.

## ACTUATED DIMENSIONS

Unit of Measure = inches  
Dimensions based on actuators used with TFM™ seats.

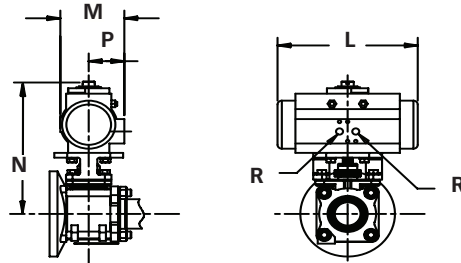

80 PSI Spring Return						60 PSI Spring Return					80 PSI Double Acting					60 PSI Double Acting				
Size	L	M	N	P	R	L	M	N	P	R	L	M	N	P	R	L	M	N	P	R
1/2"	5.55	2.8	5.84	1.61	1/8 NPT	6.46	3.17	6.29	1.77	1/8 NPT	5.55	2.8	5.84	1.61	1/8 NPT	5.55	2.8	5.84	1.61	1/8 NPT
3/4"	6.46	3.17	6.44	1.77	1/8 NPT	6.46	3.17	6.44	1.77	1/8 NPT	5.55	2.8	5.99	1.61	1/8 NPT	5.55	2.8	5.99	1.61	1/8 NPT
1"	8.27	3.72	7.8	2.07	1/8 NPT	8.27	3.72	7.8	2.07	1/8 NPT	5.55	2.8	6.64	1.61	1/8 NPT	5.55	2.8	6.64	1.61	1/8 NPT
1-1/2"	10.83	4.84	10.15	2.68	1/4 NPT	10.83	4.84	10.15	2.68	1/4 NPT	6.46	3.17	8.39	1.77	1/8 NPT	8.27	3.72	9.1	2.07	1/8 NPT
2"	10.83	4.84	10.46	2.68	1/4 NPT	13.11	5.39	11.82	2.87	1/4 NPT	8.27	3.72	9.41	2.07	1/8 NPT	8.27	3.72	9.41	2.07	1/8 NPT
3"	14.65	5.83	14.29	3.15	1/4 NPT	17.15	6.46	15.18	3.44	1/4 NPT	13.11	5.39	13.81	2.87	1/4 NPT	13.11	5.39	13.81	2.87	1/4 NPT



<http://www.pbmvalve.com/valves/tank-bottom-valve-0>

<http://pbmvalve.com/maintenance-instructions>

[www.PBMValve.com](http://www.PBMValve.com)

PBM, Inc. • 1070 Sandy Hill Road, Irwin, PA 15642

Phone: 800.967.4PBM • 724.863.0550

E-mail: [info@pbmvalve.com](mailto:info@pbmvalve.com)

