



Clean Steam Trap Ball Valves



Clean Steam Trap Connection

2-way sanitary Steam Trap valves use body purge port and ball purge holes to direct flow to the trap while shutting off flow downstream. Permits sampling of steam for purity and safely isolates trap for ease of maintenance.

Deadleg piping is reduced where condensate can cool and cause contamination. These valves perform three functions and also reduce costs by eliminating unnecessary welds, "T"s and piping.

Sizes:

- 1/2" - 2"

Materials:

- 316L S/S
- Hastelloy® C276 & C-22®
- Titanium
- Others

Options:

- Actuation
- Polishing
- Vertical or horizontal installation

Trap Position

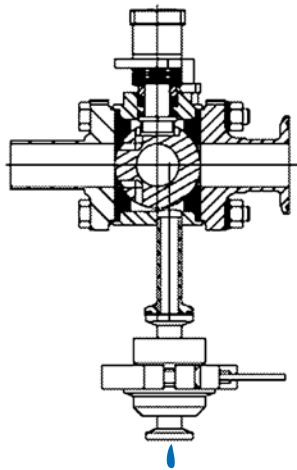

Condensate draining through trap

Open Position

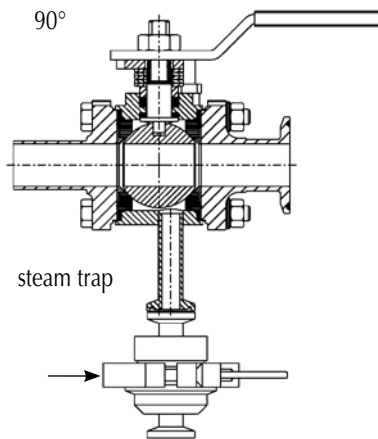

steam trap

Service Position

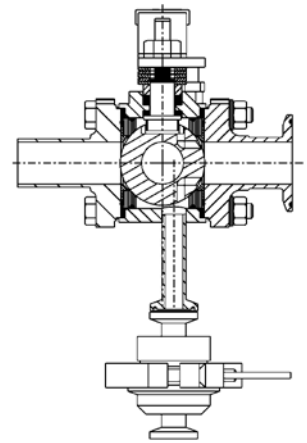

Trap can be removed for service

The **Trap Isolated Position** allows condensate to flow past the ball purge holes during normal operation, bypassing the upstream seat. Condensate flows past the purge holes in the ball and out the side port of the valve to the steam trap, allowing the body cavity to remain hot. The point-of-use, or sampling connection, is isolated by the surface of the ball without the purge holes pressing against the downstream seat.

The **Open Position** allows the flow of steam. Appropriate sampling piping or equipment connections are made at the point-of-use port, and the ball is turned 90° counterclockwise, opening the valve. The trap is isolated from flow allowing full sterilization temperature to be quickly reached. The valve is then turned 90° clockwise to return the steam trap to service in the "Trap" position.

The **Closed or Service Position** allows steam trap maintenance by turning the ball 180° counterclockwise from the normal "Closed" position to the "Trap Isolated" position. As the ball is closed toward the steam-in port, it isolates the steam trap. Maintenance can then be performed on the steam trap. To return the trap to service, the ball is turned 180° clockwise to the "Trap" position.