



IMI PBM Manual and Automated Pinch Valves PV Series 1, 1/2" and 1"

General:

This Installation, Operation, and Maintenance manual is for the safe use of IMI PBM manual and automated PV Series 1 pinch valves. Please read all instructions carefully and save for future reference.

Installation:

IMI PBM manual and automated PV Series 1 pinch valves can be installed using the four #10-32 UNF or M5 coarse thread machine screws taps located at the base of the pinch valve. The manual pinch valve has four #10-32 UNF (M5 coarse thread) taps on the bottom of the body of the pinch valve, while the actuated pinch valve has the body taps as well as four #10-32 UNF (M5 coarse thread) taps on the actuator of the pinch valve. Refer to the respective assembly drawing for detail mounting pattern dimensions. Once panel mounted, the pinch valve safety cover nut can be unscrewed and the safety cover can be raised up to insert flexible hose / tube) the body. For the manual pinch valve, the handle can be turned to the fully open position, indicated by the green marking on the stem, and then the hose can slide into the pinch valve body by gripping each side and sliding into the slot avoiding any bodily contact with the valve. For the actuated pinch valve a minimum of 60 psig of air can be applied to the actuator to open the pinch valve, the safety cover and nut can be slid off of the body and then the hose can be carefully slid into the pinch valve body, again avoiding bodily contact with the valve body.



Care must be taken when installing the hose into the body because the safety cover must be raised for clearance. When loading the hose or tube, do so by gripping the hose on each side and sliding into the slot in the valve body housing avoiding any bodily contact with the valve. Once the hose has been installed into the pinch valve body, the safety cover must be lowered over the body and hose and the safety cover nut must be screwed back on to secure the safety cover prior to operation. Use only safety cover with port size intended for the specific hose / flexible tube OD (see table below).

WARNING

For your safety and protection it is important that the following precautions be taken prior to working on the valve.

1. Do not operate IMI PBM Manual and Automated Pinch valves without the safety cover installed and secured.
2. When loading / removing hose or tube from the valve, do so by gripping the hose on each side of the valve body slot in the valve body housing avoiding any bodily contact with the valve.
3. Depressurize and drain the hose or flexible tube
4. Disconnect any air and electrical connections to the valve assembly.
5. Know what the media is in the line and wear appropriate protective clothing and equipment. Obtain appropriate MSDS sheets.
6. Remove the hose / tubing with caution
7. Refer to the hose / flexible tubing manufacturer's recommendations for proper use, safety, application, and disposal
8. To ensure safe product selection and operation, it is the responsibility of the process system designer and end user to determine the appropriate compatible materials of construction and adequate product ratings for the process system. Process system designer, installer, and end user are responsible for proper installation, operation, and maintenance.
9. When disposing of elastomer parts, do not incinerate or subject to open flames. For tube /flexible hose disposal, refer to the manufacturer's recommendation

Process Automation

Our product brands:
IMI PBM



WARNING:

Use only the appropriate safety cover port size as recommended below to allow clearance for hose / tube. Never attempt to use a safety cover that is not sized specifically for the hose or flexible tube OD used. This code is the last 2-digits of the part number on the pinch valve nameplate.

Code	Safety Cover Port (hose OD)		Safety Cover Part Number
02	For 0.272" OD hose	For use with 1/2" Pinch Valve Size	PAVCC111102
03	For 0.355" OD hose		PAVCC111103
04	For 0.447" OD hose		PAVCC111104
05	For 0.500" OD hose		PAVCC111105
06	For 0.625" OD hose		PAVCC111106
07	For 0.750" OD hose		PAVCC111107
08	For 0.875" OD hose		PAVCC111108
10	For 1.000" OD hose		For use with 1" Pinch Valve Size
11	For 1.125" OD hose	PAVCC111111	
12	For 1.125" OD hose	PAVCC111112	
13	For 1.375" OD hose	PAVCC111113	

Operation:

For manual pinch valves, operation consists of turning the handle in the counter clockwise direction to open the pinch valve and clockwise to close the pinch valve. For automated pinch valves the operation is controlled by the spring return actuator. When a minimum of 60 psig is supplied to the actuator then the pinch valve will open. When air is not supplied to the actuator, the pinch valve will be closed by the force of the springs. When loading the hose or flexible tube, do so by gripping the hose or flexible tube on each side and sliding into the slot in the valve body housing avoiding any bodily contact with the valve.

Part List	
Item	Description
1	Nameplate
2	Safety Cap Retaining Nut
3	Knob
4	Stem
5	Plunger
6	Body
7	Safety Cap
8	O-Ring
9	Set Screw
10	Rotor Clip Retaining Ring

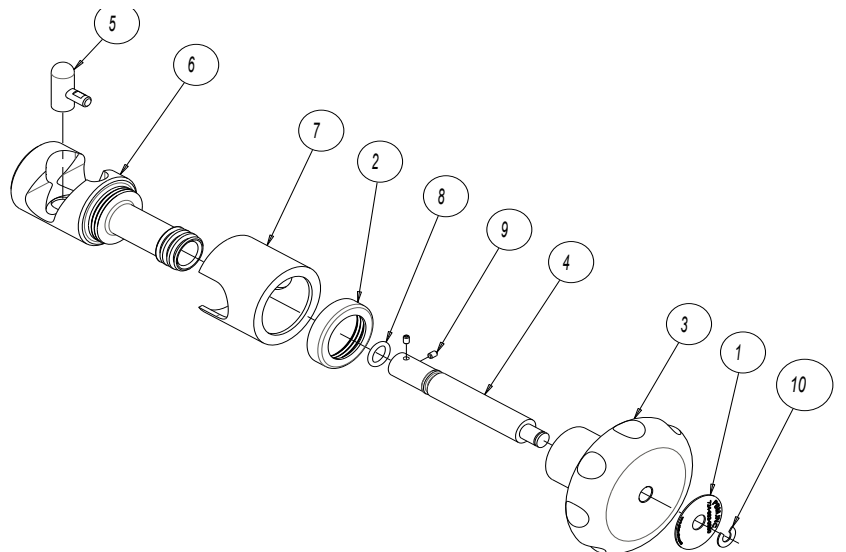

WARNING:

NEVER INSERT FINGERS OR ANY BODY PART INTO THE PINCH VALVE BODY.

When removing the hose or flexible tube, do so by gripping the hose or flexible tube on each side and sliding hose or flexible tube out of the valve body housing avoiding any bodily contact with the valve.

Disassembly of Manual Pinch Valve:

1. Remove the rotor clip retaining ring from the stem on top of the handle.
2. Slide the nameplate off of the stem and turn the knob until it unscrews from the body and off of the stem.
3. Unscrew the safety cap retaining nut from the body and slide both the retaining nut and the safety cap off of the body.
4. Remove the two set screws that hold the plunger onto the stem.
5. The stem will then slide out of the pinch valve body and the o-ring can be removed from the stem.
6. Next the plunger can be removed from the body of the pinch valve.

Reassembly of Manual Pinch Valve:

1. Before reassembling the pinch valve, examine the parts and repair or replace damaged or worn parts. Clean metal parts, as necessary, using a solvent compatible with the process and a non-abrasive cloth. IMI PBM recommends using new seals at each assembly.
2. The o-ring can be inserted onto the stem and the stem can then be inserted into the body of the pinch valve.
3. The plunger can then be put back into place in the body and inserted back onto the stem.
4. Replace the two set screws on the stem.
5. Slide the safety cap and retaining nut back onto the body of the pinch valve and secure the retaining nut by screwing into place.
6. Thread the knob back onto the pinch valve body and over the stem, then slide the nameplate back into place and attach the rotor clip to the stem.

Parts List	
Item	Description
1	Spring Housing End
2	Pinch Valve Body Retaining Clamp
3	Spring Housing
4	Piston Housing
5	Piston Rod
6	Pinch Valve Body
7	Plunger
8	Safety Cap Retaining Nut
9	Safety Cap
10	O-Ring
11	O-Ring
12	Set Screw
13	End Cover Retaining Screw
14	Housing Lock Washer
15	Retaining Clamp Lock Washer
16	Housing Cap Screw
17	Retaining Clamp Screw
18	Rod End Cover
19	Clamp Gasket
20	Outer Spring

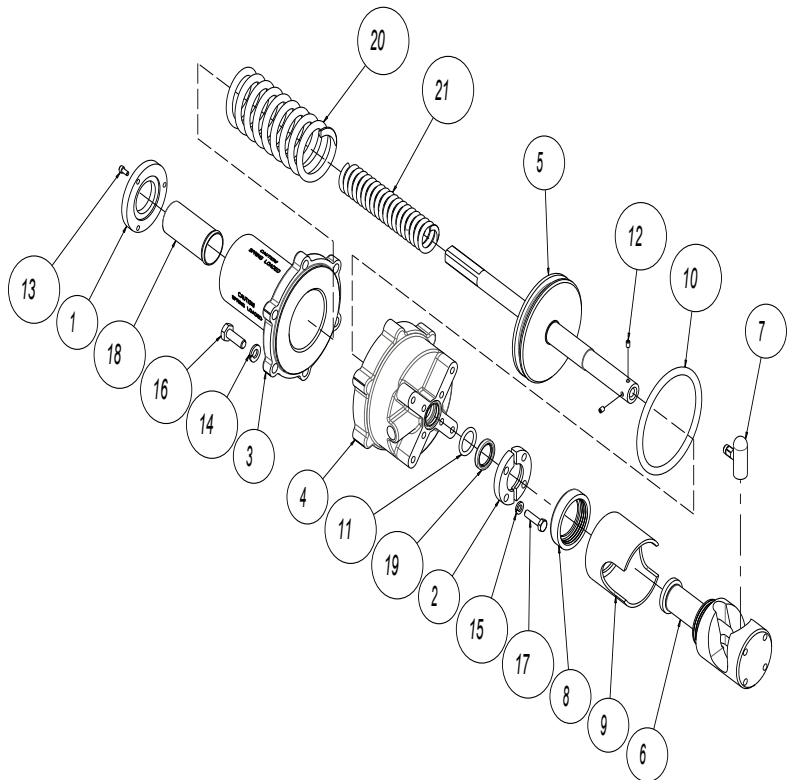

Disassembly of Automated Pinch Valve:

1. Supply a minimum of 60 psig air to the actuator and unscrew the safety cap retaining nut from the body and slide both the retaining nut and the safety cap up the body.
2. Carefully remove the hose from the pinch valve body and actuate the pinch valve closed. Care must be taken when removing the hose from the body. NEVER INSERT FINGERS OR ANY BODY PART INTO THE PINCH VALVE BODY.
3. Disconnect any air or electrical connections to the pinch valve. Before disconnect, verify that the pinch valve body is free any obstructions.
4. Remove the two set screws that hold the plunger onto the piston rod.
5. Remove the four retaining clamp cap screws from the retaining clamp and piston housing, then remove the retaining clamp. Once the retaining clamp is removed then the pinch valve body and plunger can be removed.
6. At this point the pinch valve safety cap and retaining nut can be removed from the pinch valve body.
7. The six housing cap screws can then be carefully removed from the spring housing and piston housing.

WARNING:

Care must be taken when removing cap screws because the actuator housing assembly is spring loaded NEVER INSERT FINGERS OR ANY BODY PART into pinch valve body.

- a. To safely remove cap screws: First remove two of the cap screws that are opposite each other.
 - b. Next, replace two pieces of 3-4" long, 1/4"-20 UNC all-thread where the two cap screws were located and screw 1/4"-20 UNC hex nuts down on each piece of all thread.
 - c. The other four cap screws can be removed from the actuator assembly.
 - d. Next, begin loosening the hex nuts on the all thread, slowly opening the actuator assembly.
 - e. Once the springs are no longer applying pressure on the actuator housings, the all-thread can be removed.
8. Once the cap crews are removed from the actuator housing then the spring housing can be pulled apart from the piston housing. This will reveal the piston rod assembly and the compression springs inside the housing.
 9. The inner and outer compression springs can be removed from the housing as well as the piston rod assembly.
 10. The o-ring on the piston rod assembly can then be removed from the piston rod.
 11. Inside the piston housing, in the bore that the piston slides through will be an o-ring groove with another o-ring in the groove. This o-ring can also be removed from the piston housing.
 12. On top of the spring housing is the spring housing end which is fastened to the spring housing using three retaining screws. These can be removed and the spring housing end can be taken off of the spring housing, along with the rod end cover.

Reassembly of Automated Pinch Valve:

1. Before reassembling the pinch valve, examine the parts and repair or replace damaged or worn parts. Clean metal parts, as necessary, using a solvent compatible with the process and a non-abrasive cloth. IMI PBM recommends using new seals at each assembly.
2. The small o-ring that goes into the piston housing can be inserted into its groove in the piston housing.
3. The larger o-ring can be placed back on the piston rod assembly and the piston rod assembly can be inserted back into the piston housing.
4. Next, the inner and outer compression springs can be placed into the spring housing and the spring housing and piston housing can be reassembled using the six housing cap screws and lock washers. Care must be taken when assembling the actuator housing because the actuator housing assembly is spring loaded.
 - a. Next, place two pieces of 3-4" long, 1/4"-20 UNC all-thread opposite each other where two cap screws were located and screw 1/4"-20 UNC hex nuts down on each piece of all thread.
 - b. Slowly screw the hex nuts down on each piece of all-thread until the actuator housing closes.
 - c. Next, place four of the 1/4"-20 UNC cap screws and lock washers in their respective holes and tighten them in place.
 - d. The all-thread can then be removed and in its place the remaining two 1/4"-20 cap screws and lock washers can be tightened down.
5. Reassemble the spring housing end and rod end cover to the spring housing using the three end cover retaining screws.
6. Slide the safety cap and safety cap nut over the pinch valve body and place the clamp gasket between the pinch valve body and piston housing in the appropriate groove.
7. Slide the pinch valve body onto the piston rod, once the set screw holes in the piston rod are visible through the body, slide the plunger into place in the piston rod and tighten the set screws that secure the plunger in place.
8. Attach the pinch valve body to the piston housing using the retaining clamp screws and lock washers.
9. The safety cap and safety cap retaining nut can now be secured in place over the pinch valve body.