



IMI PBM

Full Port Ball Valves, FI, FT, SI, SP Series 6, 1/2" thru 4" Fire-Safe per API-607

Installation, Operation and Maintenance Instructions

General:

This Installation, Operation, and Maintenance manual is for the safe use of IMI PBM 3-piece, Non Adjust-O-Seal®, Bi Directional, FI, FT, SI, AND SP Series 6 ball valves. Please read the instructions carefully and save them for future reference.



WARNING

Installation:

FI, FT, SI, and SP valves may be installed in either direction with the valve in the "open" position. SI and SP valves do not need to be disassembled before installation except for socket weld end connections. For FI and FT valves, disassemble the valve and attach the tank pad to the vessel. Reassemble valve to tank pad. See IOM-WELD for welding of end connections or tank pads.

Operation:

For manual valves, operation consists of turning the handle 1/4 turn to close or open the valve. When handle is parallel with the pipeline, the valve is in the open position. These valves may also be automated with actuators and other valve automation equipment. Mechanical handle stops must be removed if manual valves are converted to automated valves. For automated valves, operation is controlled by the actuator placed on top of the valve. Valve stops are an integral part of the actuators. Good operating procedure requires periodic inspection of the valves and replacement of parts as required. Always use IMI PBM factory authorized replacement parts.

Locking Handle Device, Manual Valves Only (When Supplied)

1. Depress handle lock bar inward toward the valve stem until it clears the stop on the valve body.
2. While maintaining the handle lock bar in this position, turn handle to desired position.
3. Release the handle lock bar, ensuring that it returns to the proper position against the handle.

Follow instructions to ensure optimum performance:

Adjusting for Normal Wear

Note: Valve to be in fully opened or fully closed position prior to adjustments.

1. If valve shows signs of leakage in stem area due to normal stem packing wear, loosen the upper jam nut on the stem, then tighten the lower jam nut as follows:
 - a) For valves 2" and smaller, tighten the nut to completely compress the spring washers, then loosen nut 1/2 turn.
 - b) For valves 2-1/2" and 3", tighten the nut until a gap of about 0.05" (1.3 mm) exists between the adjacent spring washers.
 - c) For the 4" valve, tighten the nut until a gap of about 0.10" (2.5 mm) exists between the adjacent spring washers.Leakage should stop, and the valve should continue to operate smoothly.
2. After adjustments have been made and the packing leakage cannot be stopped or if there is leakage past the non-adjusting ring, a repair kit will be required.

For your safety and protection it is important that the following precautions be taken prior to working on the valve.

1. Depressurize and drain the line.
2. Cycle the valve to relieve any pressure trapped in the valve.
3. Disconnect any air and electrical connections to the valve assembly.
4. Know what the media is in the line and wear appropriate protective clothing and equipment. Obtain appropriate MSDS sheets.
5. To ensure safe product selection and operation, it is the responsibility of the process system designer and end user to determine the appropriate compatible materials of construction and adequate product ratings for the process system. Process system designer, installer, and end user are responsible for proper installation, operation, and maintenance.
6. When disposing of Teflon parts, do not incinerate or subject to open flames.

Process Automation

Parts List

Item	Description
1	Body
2	Ball
3	End Fitting
4	Gland Plate
5	Stem
6	Gland Bearing
7	Seat
8	Stem Packing
9	Spring Washers
10	Gland Bolt
11	End Fitting Fastener
12	End Fitting Hex Nut
13	Lock Washer
14	Graphite Stem Pack-ing
15	Metal Seat Ring
16	Stem Nut(s)
17	Cavity Filler
18	(If equipped)
19	Graphite Body Gasket
20	O-Ring
21	O-Ring
22	Ground Spring
23	Ground Wire
24	Handle (Manual Only)
25	Stop Pin

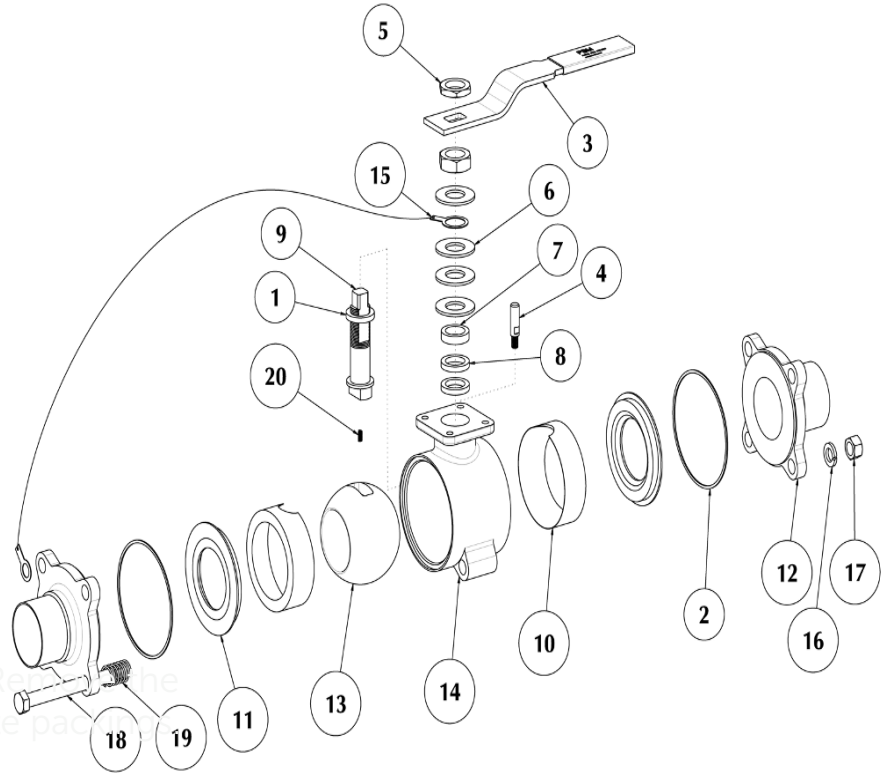

Disassembly of Valve:

- Isolate and depressurize the associated piping system. Cycle the valve to ensure there is no trapped pressure or fluid in the valve cavity. The valve should be left fully open or fully closed.
- For Automated Valves Only:** Remove all air and electrical power from the actuator, solenoid valve, and switchbox, if any. Then remove the automation assembly from the valve. Retain coupling and mounting bracket.
- For Manual Valves Only:** Loosen and remove the upper jam nut from the stem and then remove the handle.
- For valves with welded end connections, the valve can be disassembled with the body subassembly swung out from the end fittings, or it can be disassembled with the body subassembly completely removed from the end fittings.
 - In order to swing out the body subassembly from the end fittings, fully open the valve and loosen the end fitting hex nuts. Then remove the fasteners, nuts, and lock washers between the body swing out ring and the stem.
 - Spring the connecting piping 1/8" to remove the compression on the body from the end fittings.
 - Swing the body out from the end fittings until the body completely clears the end fittings. The body's swing out ring will rotate about its fastener. The sprung piping can now be returned to its original compression, if desired.
 - In order to remove the body subassembly, loosen all end fitting fasteners. Then, remove the fasteners, including the nuts and lock washers, between the body swing out ring and the stem. Remove the fastener, including tag, nut, lock washers, and external ground spring, if any, that passes through the body swing out ring.
 - Spring the connecting piping 1/8" to remove the compression on the body from the end fittings.
 - Slide the body out from the end fittings until the body completely clears the end fittings. The sprung piping can now be returned to its original compression, if desired.
- If the entire valve is to be removed from the piping, disconnect the end connections, remove the valve, then loosen and remove the body fasteners. Then pull the end fitting(s) free from the body. It may require force to remove.
- Close the valve, then remove the O-ring (from behind the metal seat ring), the metal seat ring, the graphite gasket, the seat, and the O-ring attached to the O.D. of the metal seat ring from each side of the body.
- Remove the cavity fillers (if installed) from each side of the body.
- Carefully remove the ball from the body by pushing it out one of the open ends. Take care not to nick or scratch the ball. Remove the ground spring from the underside of the stem.
- Loosen and remove the remaining jam nut and remove the spring washers, ground wire, and stem bearing.
- Loosen and remove the two cap screws that secure the gland plate, then remove the gland plate.
- Push the stem down into the body and remove it through one of the open ends of the body.
- Remove the bottom packing from the stem or the counterbore at the I.D. of the body.
- Remove the graphite packings.

Reassembly of Valve:

1. Before reassembling the valve, examine the parts and repair or replace damaged or worn parts. Clean metal parts, as necessary, using a solvent compatible with the process fluid and a non-abrasive cloth. IMI PBM recommends using new seats, body gaskets, O-Rings and seals at each assembly. The graphite packings and gaskets must be replaced at each assembly as they become damaged at disassembly.
2. Insert a new seat and cavity filler, if equipped, into the body recess with the seating surface facing towards the ball cavity.
3. Install a new packing onto the threaded end of the stem and slide it down until it contacts the shoulder.
4. Insert the stem into body bore and through the stem bore in the body.
5. Install the graphite packings onto the stem, and push the packings into the body counterbore using the gland plate.
6. Install the stem bearing onto the stem, on top of the gland plate.
7. Install a spring washer onto the stem with the concave side facing upward. Install the external ground wire terminal onto the stem such that the ground wire extends towards the end fitting side of the body
8. Install a second spring washer onto the stem with the concave side facing downward. Install the remaining spring washers onto the stem in an alternating or series arrangement. No two adjacent spring washers should be facing the same direction or in a parallel arrangement
9. Lubricate the stem threads with an anti-galling lubricant.
10. Thread a stem hex nut onto the stem. For valves 2" and smaller, tighten the nut to completely compress the spring washers, then loosen nut 1/2 turn. For valves 2-1/2" and 3", tighten the nut until a gap of about 0.05" (1.3 mm) exists between the adjacent spring washers. For valves 4" and larger, tighten the nut until a gap of about 0.10" (2.5 mm) exists between the adjacent spring washers.
11. **For Manual Valves Only:** Install the handle on the stem such that stop pin will contact the right side of the handle. Install and tighten the remaining hex nut to secure the handle to the stem.
12. Rotate the stem to the closed position of the valve. Insert the ground spring into the hole in the bottom of the stem. Rotate the stem to the closed position of the valve. Then, while holding the ball directly over the entrance to the valve body, orient the ball to the closed position, rotate the slotted end of the ball toward the stem tang located inside the valve, and insert the ball into the body. Take care not to scratch or nick the ball.
13. Rotate the stem until the ball is in the open position. Install the remaining cavity filler into the body, if equipped. Install the non adjusting ring and end body gasket onto the end fitting. Lubricate the O ring and approximately the first 1-1/2" of the body bore with a lubricant compatible with the process fluid. Install the o-ring into the groove in the end fitting.
14. Lubricate the threads of body bolting with anti-galling lubricant.
15. Install the end fitting onto the body. Install the external ground wire onto one of the adjacent end fitting fasteners. Install tagging, lock washers, and hex nuts. Hand-tighten the hex nuts.
16. Torque the body / end fitting fasteners in a staggered and incremental sequence as per the instructions on the following page. Cycle the valve to verify freedom of operation. If practical, check the valve seats and seals for leaks.
17. Reinstall the valve into the piping using appropriate gaskets and fasteners.
18. For valves with gear operators, reinstall the bracket, coupling, and gear operator.
19. **For Automated Valves Only:** Reinstall the automation assembly with the bracket and coupling. Then reconnect air and electrical power.
20. Insulate the valve, if applicable.

Tightening Procedure for End Fittings:

1. Hand tighten fasteners.
2. Wrench tighten each fastener in a staggered and incremental sequence as illustrated below until the recommended torque value in Table 2 on page 4 is achieved.

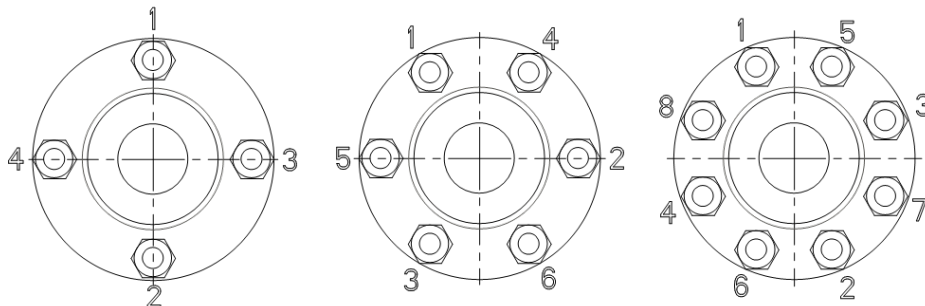

Replacement Kits and Parts						
Valve Size	SP, FT Repair Kit (V-TEF™)	SP, FT Cavity Filler Kit (VTFE)	SP Ball (316L S/S)	SI Ball (316L S/S)	Stem (316L S/S)	Spring Washers
1/2"	SPTFC6 -- G -- 1	SPTFC5 -- J -- 3	SPHLC502	SIHLC502	SPHLD505G	SPK-E110
3/4"	SPTFD6 -- G -- 1	SPTFD5 -- J -- 3	SPHLD502	SIHLD502	SPHLD505G	SPK-E110
1"	SPTFE6 -- G -- 1	SPTFE5 -- J -- 3	SPHLE102	SIHLE402	SPHLE505G	SPK-E510
1-1/2"	SPTFG6 -- G -- 1	SPTFG5 -- J -- 3	SPHLG102	SIHLG402	SPHLH505G	SPK-H510
2"	SPTFH6 -- G -- 1	SPTFH5 -- J -- 3	SPHLH102	SIHLH402	SPHLH505G	SPK-H510
2-1/2"	SPTFJ6 -- G -- 1	SPTFJ5 -- J -- 3	SPHLJ102	SIHLJ402	SPHLK505G	SPK-K510
3"	SPTFK6 -- G -- 1	SPTFK5 -- J -- 3	SPHLK402	SIHLK402	SPHLK505G	SPK-K510
4"	SPTFL6 -- G -- 1	SPTFL5 -- J -- 3	ANHLL102	SIHLL502	SPHLL505G	MPK-L110

Note for Table Above:

1. For SI, FI repair kits, change SP repair kits to begin with SI – example SITFC6--G--1.
2. Standard repair kits include 2 V-TEF™ seats, 2 graphite gaskets, 2 graphite packings, 1 V-TEF™ packing, 1 PEEK™ stem bearing, and 4 O-rings.
3. Standard repair kits and replacement parts are V-TEF™ seats and Graphite stem packings and body gasket.
4. Replacement parts are one each per part number.
5. For materials other than V-TEF™, substitute the correct material ID and code.

Material Definitions:

TF	V-TEF™	Chemically modified polytetrafluoroethylene
VT	VTFE	Virgin Polytetrafluoroethylene
HT	S-TEF®	Stainless steel reinforced polytetrafluoroethylene

Valve Size	Size Code	Fastener Torque Body / End Fitting	
		in - lbs	N-m
1/2"	C6	30	3.4
3/4"	D6	30	3.4
1"	E6	60	6.8
1-1/2"	G6	120	13.6
2"	H6	180	20.3
2-1/2"	J6	240	27.1
3"	K6	360	40.7
4"	L6	1000	112
6"	M9	720	81.3